

CONTENTOR 700L

Contentor de Carga Traseira

700L

Capacidade
em litros

38Kg

Peso do
contentor

200mm

Diâmetro
das rodas

265Kg

Carga
nominal



 **CONTEMAR**
AMBIENTAL

Descrição

Contentor de PEAD (polietileno de alta densidade) fabricado por processo de injeção, resistente a ação de raios ultravioleta (proteção anti UV).

Produto produzido conforme a Norma Técnica ABNT NBR 15911.

Contentores submetidos a todos os ensaios constante na ABNT 15911 - 3/4 e comprovado através de certificado emitido por um OCP (Organismo de Certificação de Produto).

Corpo com superfície lisa, isenta de quaisquer fissuras ou cantos pontiagudos, possui dreno e tampa. O Design do corpo do contentor possui um detalhe para montar a placa de rodízios sem a perfuração do recipiente.

Receptor frontal do tipo B para encaixe de pentes, receptor lateral do tipo A, resistentes à coleta mecanizada.

Rodas: Possuem 4 rodas, 200mm de diâmetro, revestidas de borracha maciça, núcleo de polipropileno e sem freios, feito através de rolamento de duas pistas de esferas cementadas, sendo um conjunto de duas traseiras com freios

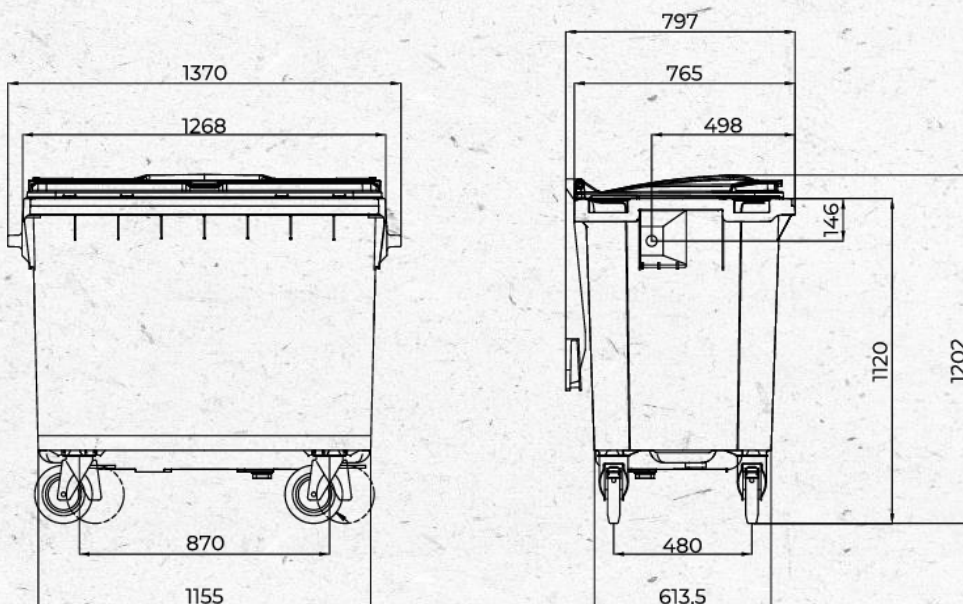

Certificação



Atributos do Produto



Qualidade

 2 ANOS
GARANTIA

Proteção UV

Personalize seu produto como desejar



Pedal

 Cores do
produto

 Boca Seletiva
(sob consulta)

 Termo
Impressão
(sob consulta)

 Serigrafia
(sob consulta)

 Fechadura
(sob consulta)

Munhão

 Munhão
Stopper

 Sobre Tampa
(sob consulta)

Equipamento

Rodas de 200mm de diâmetro que não deixam marcas e nem fazem barulho, 360º de giro, com duas rodas possuindo freios.

Possibilidade de equipar seu contendor com diversos acessórios e melhorar a usabilidade do produto.

 Polietileno de alta
densidade

Fácil de limpar

 Fácil
manipulação

Freios

 Resistente a
intempéries

Personalizável

 Tampa
silenciosa

 Design moderno
e funcional

 Peças de
reposição